

SPRIZ

The VENIX logo features a stylized white flame icon above the word "VENIX" in a bold, white, sans-serif font, set against a red background.

**HIGH-SPEED
CONVECTION OVEN
FOR QUICK SERVICE**





SPRIZ

HIGH SPEED CONVECTION OVEN WITH NEW CONCEPT FOR ACCELERATED COOKING PRODUCTS

Today, there is a need for fast, easy-to-use, versatile, and affordable products. Venix understands this well and has created a range of professional ovens with “impingement” technology and forced ventilation, which allows great dishes to be prepared in just a few minutes.

SPRIZ is the perfect solution for baking pre-cooked products like pizzas and sandwiches or for heating frozen items.





IDEAL APPLICATION

- Petrol station
- Convenience stores
- Coffee Shops
- Quick service restaurants
- Healthcare
- Hotel room service
- Stadiums
- Theaters
- Kiosk



FEATURES & BENEFITS

- **FAST COOK TIME RESULTS:** Frozen pizza 30 cm in 2:40 minutes.
- **SPACIOUS INTERIOR SPACE:** Up to 4 sandwiches per times.
- **SAFETY "COOL DOOR":** With double glass and possibility of seeing the products inside the cooking chamber.
- **LED LIGHTING IN THE DOOR:** For cooking chamber illumination.
- **SPACE-SAVING:** Effective space-saving design.
- **MULTI-LANGUAGE:** Multi-language operation display.
- **EASY CLEAN SYSTEM:** Clean System with rounded edge in the cooking chamber thanks also to a special tray that collects food residues.
- **HOLDING TEMPERATURE SELECTOR:** To maintain the temperature of cooking chamber for quick starting.

COOKING TECHNOLOGIES

- **CONVECTION COOKING:** Single Phase
- **IMPINGEMENT TECHNOLOGY:** Improves toasting and browning.
- **DIGITAL 2,4 LCD CONTROL:** Color LCD 2,4" screen with 100 programs and 6 fast selection programs.
- **WEB SERVER:** Easily connect to smartphones and tablets to access the menu recipe book.
- **USB PORT:** Upload/download menu items easily.
- **WI-FI / CLOUD:** The connection with the Cloud allows both remote assistance and maintenance. Add menu items to every location within a matter of minutes.

*Pre-cooked
Frozen pizza*



2' 40"
1 PC

*Chicken
Wraps*



3'
2 PCS

*Ham and cheese
Toast sandwich*



2' 50"
4 PCS

Nachos



45"
300 GR

DIGITAL 2,4" LCD CONTROL PANEL

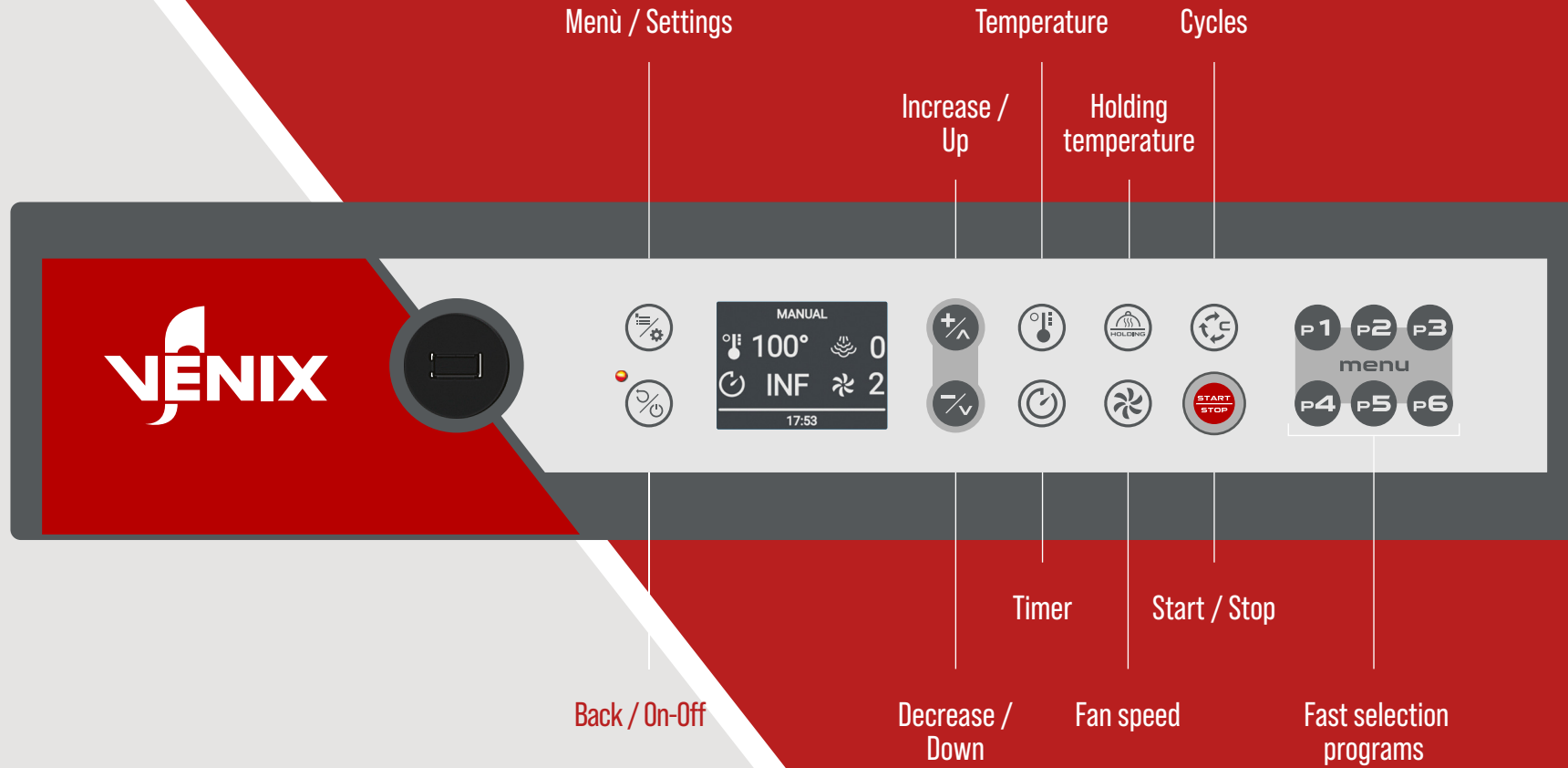

**DIMENSIONAL
DRAWINGS**

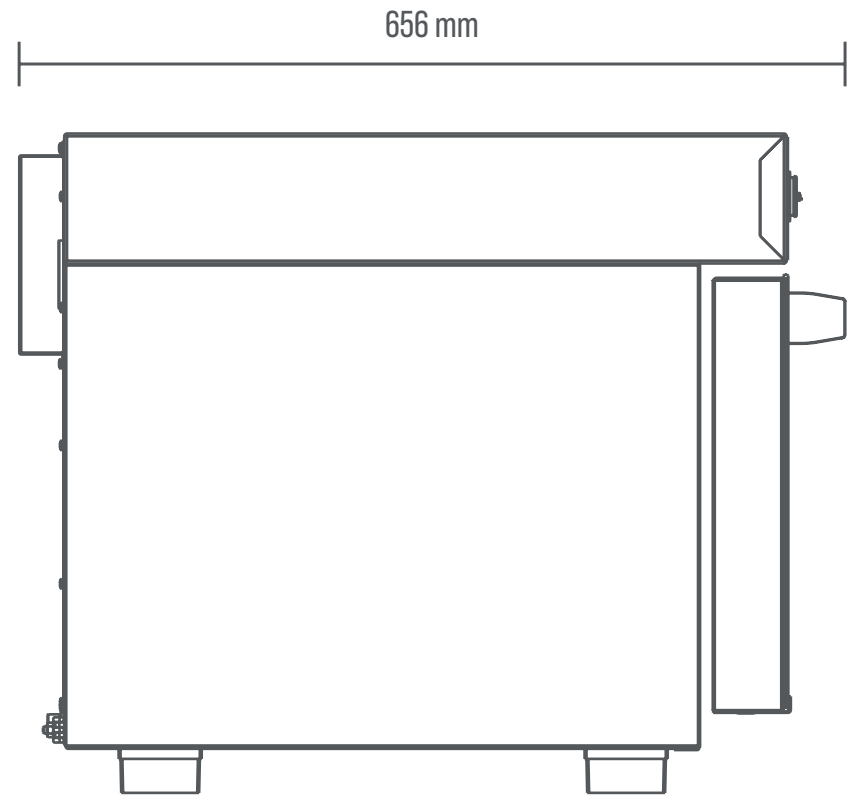
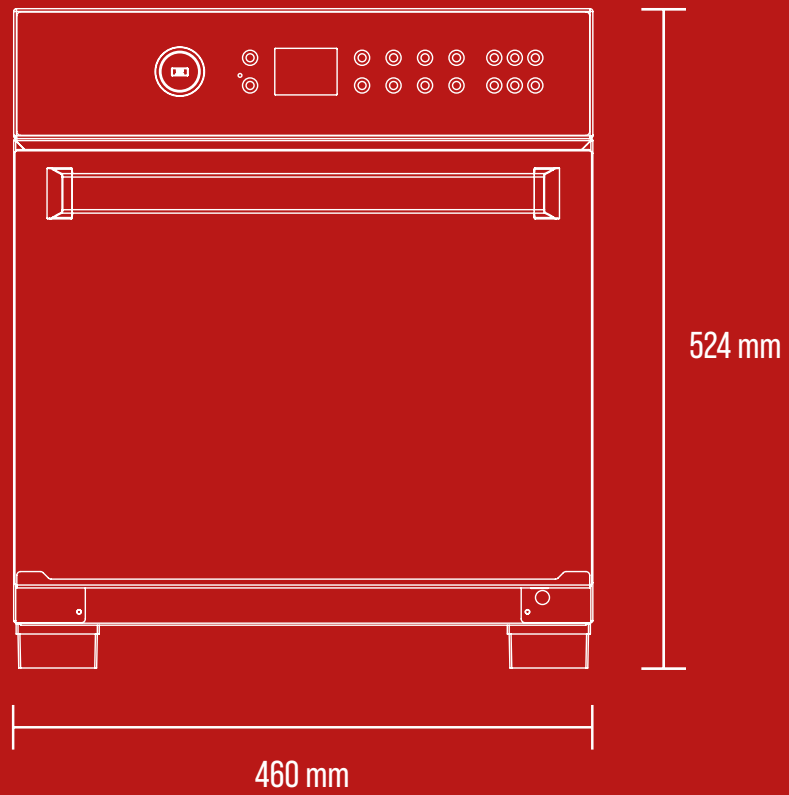

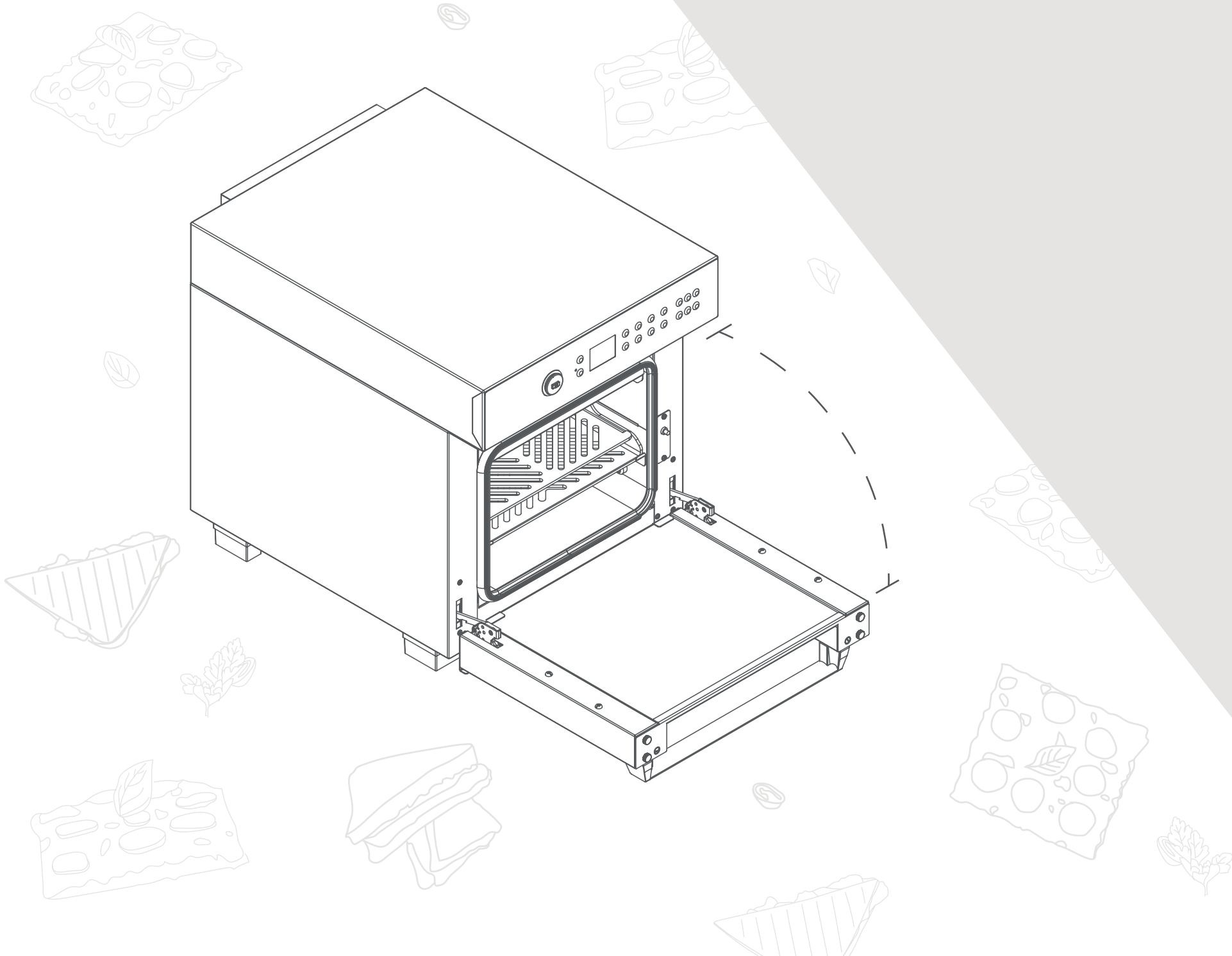



venix.it

